

## A "Large Crystal" Scintillation Scanner<sup>1,2</sup>

T. D. Craddock,<sup>3</sup> B.Sc., M.Sc., S. O. Fedoruk,<sup>4</sup> M.A.,  
and J. A. MacKay<sup>5</sup>

*Saskatchewan, Canada*

### INTRODUCTION

For a number of years isotope scanning techniques have been increasingly used by physicians as a diagnostic procedure. Parallel to this development of techniques has been the development of increasingly sensitive detectors and increasingly accurate scanning machines. Scans of the thyroid may be performed fairly readily with scanners using small crystals but more sophisticated scanners are required when isotope investigations are extended to include more deeply situated and, or, larger organs. This paper describes one such scanner which embodies many improvements designed to give it sensitivity, fine spacial resolution and versatility, so that it is capable of producing scans of deep seated organs such as the liver, pancreas or kidneys.

A large crystal with adequate shielding was dictated by the desire to increase the detector sensitivity and by the fact that such a crystal also allows collimators to be used which have their volume of maximum response deep in the patient's tissue. With a sufficiently thick collimator such a detector can be used for isotopes of higher energy such as  $\text{Ca}^{47}$  and  $\text{Fe}^{59}$ .

The detector and its shielding weigh about 1750 lbs. which presented a problem if such a unit was to be moved with any degree of accuracy and repeatability. A new scanning mechanism was designed to cope with this task and the capacity for performing profile scans with the same equipment has also been provided.

There has always tended to be an inherent loss of information in most data-handling and picture-forming techniques, so a magnetic tape is used to store all the scan information (*e.g.* rectilinear co-ordinates and counts) which will then be available if further picture reproduction is deemed necessary. The only loss of information is therefore in the final picture-forming process. Patients need only to be re-scanned if the uptake of material is poor so that no scan picture results and not, for example, because of some error in background suppression or contrast enhancement of the scan picture.

<sup>1</sup>From the Saskatoon Cancer Clinic, Saskatoon, Saskatchewan, Canada.

<sup>2</sup>Research Grants-in-Aid from the National Cancer Institute of Canada.

<sup>3</sup>National Cancer Institute of Canada Research Fellow in Radiation Physics.

<sup>4</sup>Senior Physicist, Saskatoon Cancer Clinic, Asst. Prof. University of Saskatchewan.

<sup>5</sup>Acme Machine & Electric Co., Ltd., Saskatoon, Saskatchewan.

Finally, the photo-scan may be displayed at life size on a television screen and by adjusting the levels of the brilliance and contrast controls it is possible to emphasize small differences in count rate. This technique enables one to determine the overall size of the organ when the brilliance is set high and then to determine the areas of abnormal uptake or non-functioning tissue as the brilliance is decreased.

#### THE SCANNING MECHANISM

Figures 1 and 2 show the scanner and indicate in a simple manner how it operates. The detector head is mounted in a yoke and suspended by means of telescoping tubes from a track mounted on the support beams of the building. The head is counterbalanced with lead weights behind a dummy wall so that an

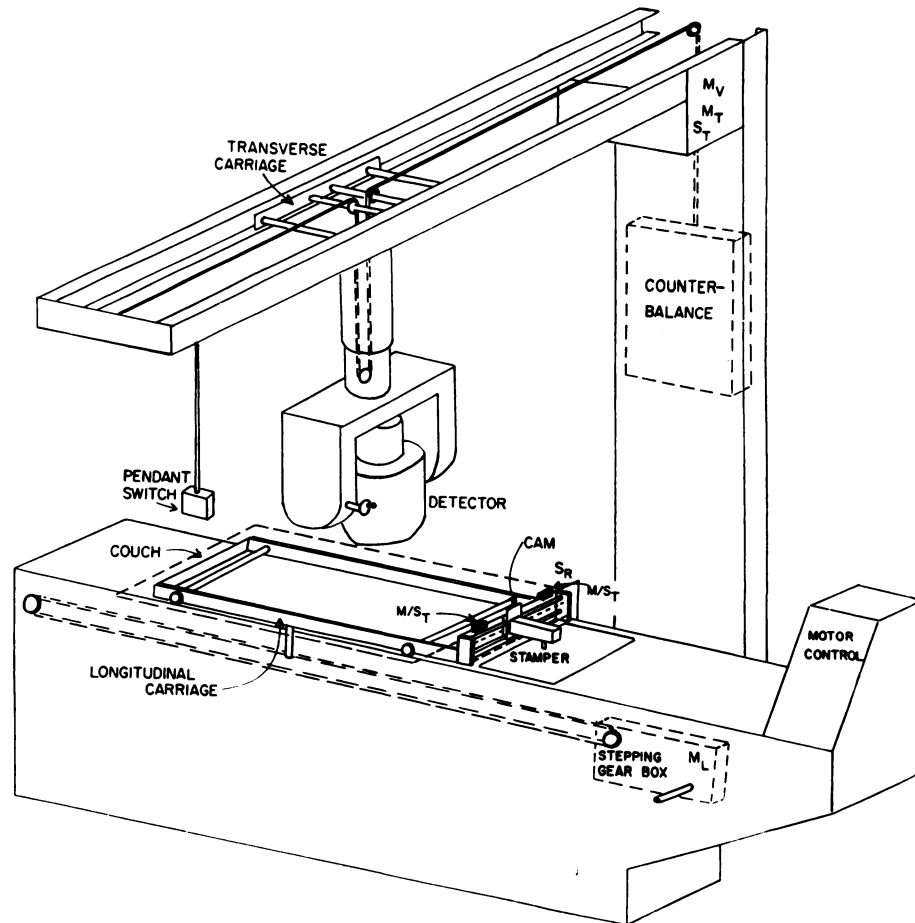
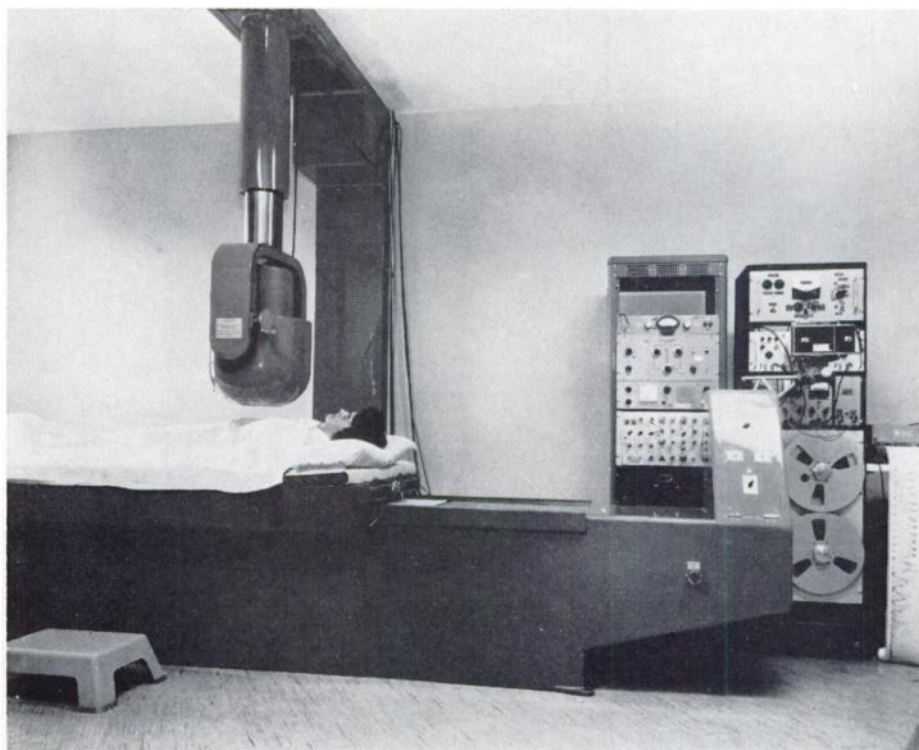

Fig. 1. Sketch of scanner to show mode of operation. The detector moves backwards and forwards across the patient under the control of motor  $M_T$  whilst the patient moves in steps at the end of each line of the scan under the control of motor  $M_L$  and the stepping gear box.

electric motor ( $M_v$ ) can easily raise or lower it. The transverse motion of the head is produced by a D.C.-controlled variable speed motor ( $M_T$ ) driving the carriage by means of a chain drive. The motion of the detector is repeated at the foot of the patient's couch by means of a selsyn synchro-link ( $S_T$  and  $S_R$ ) driving a cam mounted on slide rods. This cam follows the movement of the detector head and actuates limit switches ( $M/S_T$ ) to initiate the stop and reversal of its movements. The speed of the transverse motion is continuously variable from 0 to 6.25 cm per sec. The limit switches ( $M/S_T$ ) may be set to give any desired width of scan up to 24 inches.

The patient lies on a couch set up at right angles to the line of motion of the detector. This couch is mounted on a firm track and can be operated in one of three ways: manually controlled for setting up the patient, automatically in steps of  $\frac{1}{2}$  cm, 1 cm or 2 cm (depending on the gear selected) at the end of each transverse scan by the detector or continuously at a variable speed (0 to 2.25 cm/sec). The motor driving the couch ( $M_L$ ) also has a D.C. variable speed control.

By separating the two movements required for a rectilinear scan and by designing each very carefully it has been possible to develop a scanner which



**Fig. 2.** The large crystal scanner together with its auxiliary electronic equipment. The right hand rack contains (from top to bottom) the data-processing unit, the oscilloscope and camera, the tape recording and playback amplifiers and the tape deck. The paper chart recorder is on the far right.

demonstrates not only a high degree of mechanical accuracy and repeatability, but also useful versatility.

The transverse position of the head and longitudinal position of the patient are monitored for magnetic tape recording purposes by means of two 40-turn Helipot attached to the respective gear boxes. D.C. voltages are recorded on magnetic tape by a pulse-frequency modulation technique, so that on playback these voltages, when applied to the horizontal and vertical amplifiers of an oscilloscope, give a spot position which corresponds to the detector-couch position.

#### DETECTION SYSTEM

The scintillation detector is a Harshaw integral unit consisting of a  $5\frac{1}{2}'' \times 4''$  thick thallium-activated sodium iodide crystal and a DuMont 6393 photomultiplier tube. Since the detecting crystal is large and highly sensitive it has been mounted within a large lead shield which guarantees at least six inches of lead

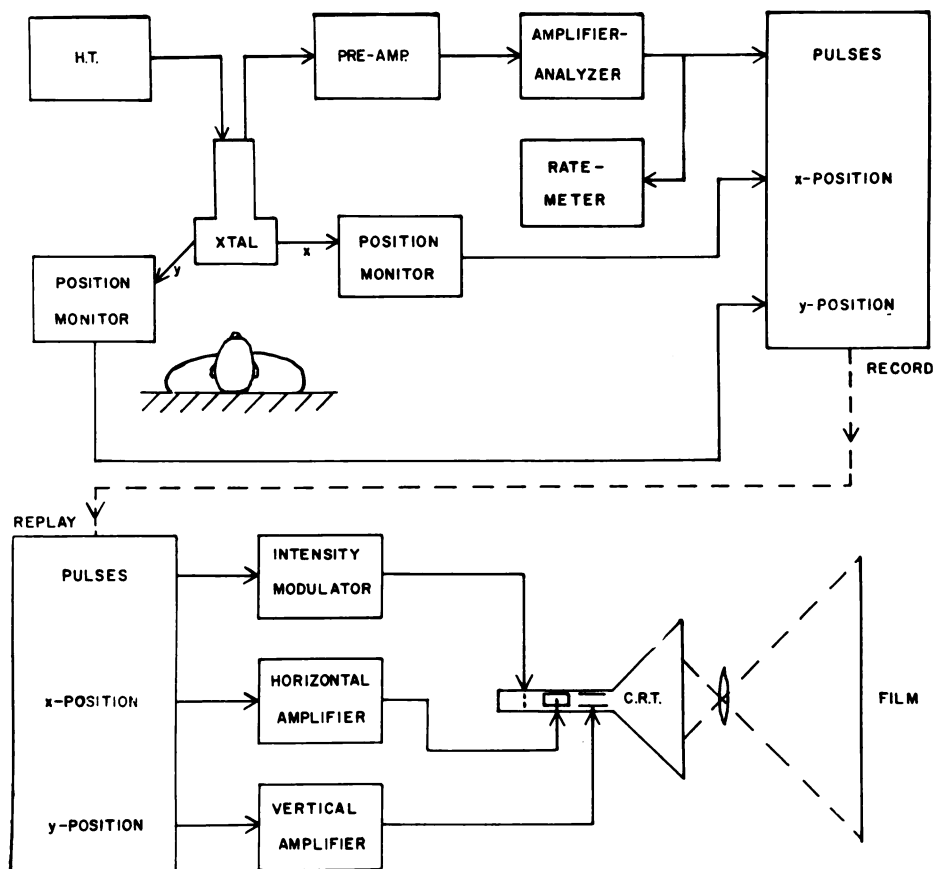

Fig. 3. A block diagram of the data-handling system. The pulses are recorded directly whilst the D.C. voltages from the position monitors are recorded by a pulse frequency modulation technique.

around the crystal itself and three inches around the photomultiplier tube. Such a high degree of shielding reduces the count rate from natural background radiation to less than 20 c.p.m. when the channel width is set to accept the 364 Ke V peak of  $I^{131}$ , so that most of the radiation detected by the crystal must reach it via the collimator opening. Various collimators may be inserted into the front face of this shield depending upon the response desired.

If full use is to be made of the increased sensitivity of the crystal by virtue of its size it is necessary to take considerable care in designing the collimators for use with this scanner. With this in view a series of experiments was performed

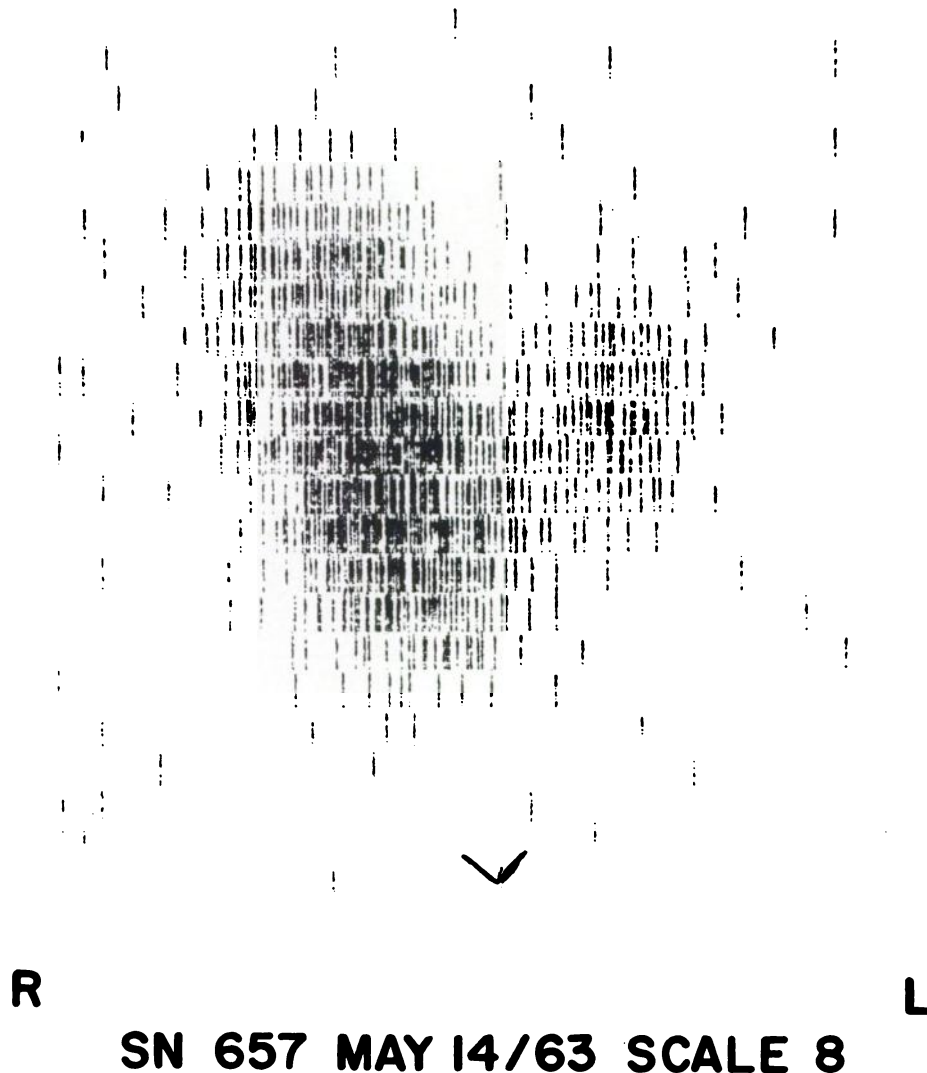

Fig. 4. A dot-scan of a patient's thyroid. The lack of "dots" outside the immediate area of the thyroid is indicative of the low background level of this detector.

to compare the responses of various types of collimator with the theoretical responses previously calculated by Brownell (1). These experiments and the results have been reported elsewhere (2) so it will suffice to say that the 50 per cent iso-response curves for a 19-hole collimator have a diameter of about 18 mm at the level of maximum response and that a 37-hole collimator has a 50 per cent iso-response curve resolution of about 13 mm at the same level. In tissue the level of maximum response is about 10 cm ahead of the front face of the collimator. With such resolutions one should (theoretically) be able to discern irregularities of about 15 mm diameter within a volume of otherwise homogeneous distribution.

#### DATA PRESENTATION

A solenoid-actuated stamper is attached to the cam at the foot of the patient couch which repeats the detector motion (Fig. 1). This stamper may be set to operate once for every 2, 4, 8, 16, 32, 64 or 128 counts from the detector and

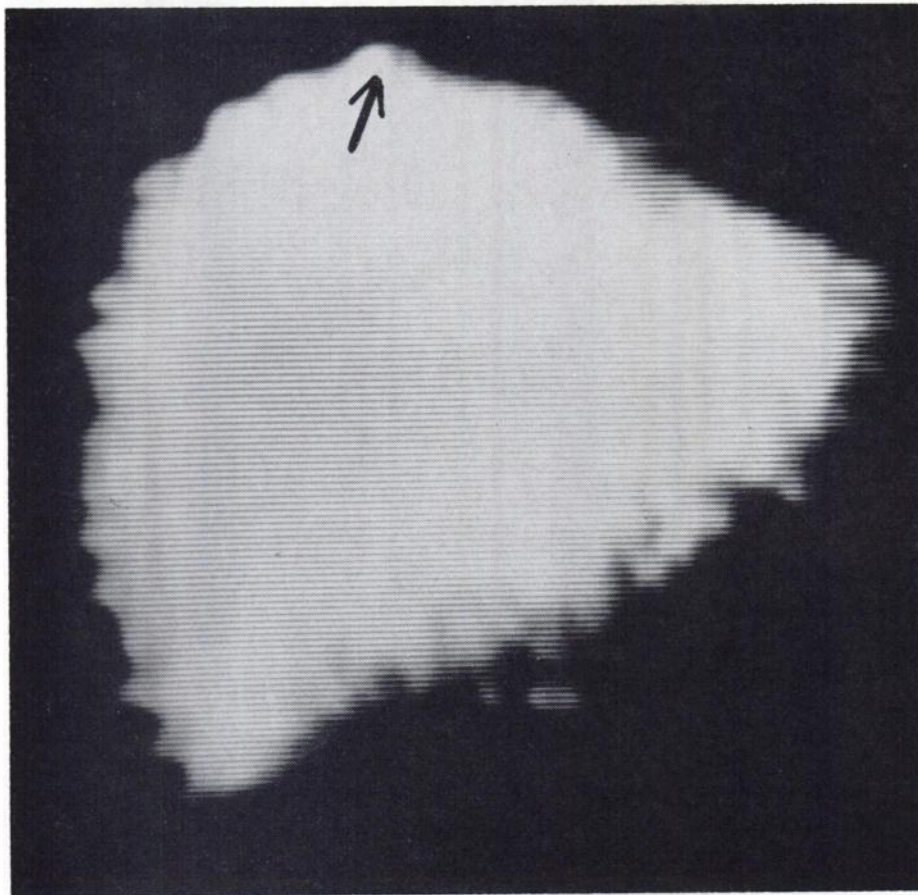
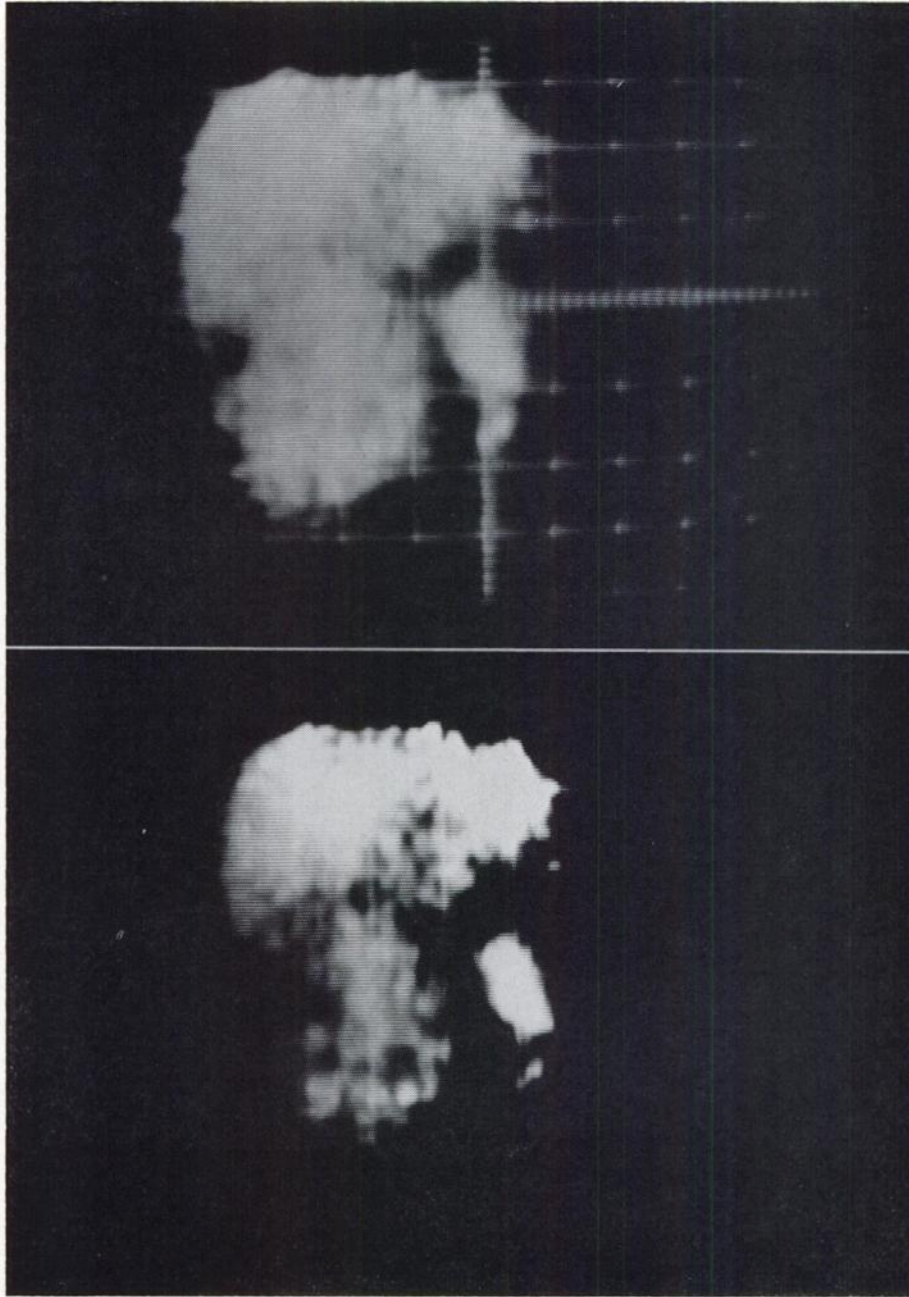

Fig. 5. Photoscan of a normal liver. The 4th intercostal space is indicated by the arrow.





**Fig. 6.** Photoscans of a liver with multiple metastases. The upper picture is produced with a low level of contrast on the T. V. set to give the overall size of the organ. When the contrast is increased the lower picture results and this shows the lesions to a more marked degree.

by so doing is capable of producing a dot scan record (Fig. 4). The stamper actuating circuit and stamper are capable of stamping 60 counts per second so that large changes in count rate may be accommodated by this unit. This read-out system gives a very useful one-to-one ratio with the structure being scanned and in particular enables the size of the thyroid gland to be determined for treatment purposes. The stamper consists of a modified solenoid as suggested by C. C. Harris of Oak Ridge in a private communication and the actuating circuit is a transistorized version of his own tube circuit.

In addition to this there is a data-handling and picture-reproduction system for the production of photoscans. The principles of the photoscan system are shown in block diagram form in Figure 3. The x- and y- position monitors consist of two 10,000-ohm 40-turn Helipot potentiometers which are driven by the transverse and longitudinal drive mechanisms. The D.C. voltages, varying between 10V negative and 10V positive, which are derived from these potentiometers correspond to the detector-patient position and are recorded on two separate tracks of magnetic tape at a speed of 3 $\frac{1}{2}$  inches per sec. by a pulse frequency modulation system. The pulses from the detector are recorded by a direct recording process after pulse height analysis and suitable amplification and lengthening.

Either during initial recording or on playback at 3 $\frac{1}{2}$ , 30 or 60 inches per sec. the two position signals are demodulated to produce D.C. voltages and these are used to vary the position of the beam of an oscilloscope by application to the X- and Y-deflection amplifiers. The scintillation pulses are passed through



Fig. 7. Photoscan of a liver with metastases from carcinoma of the lung.



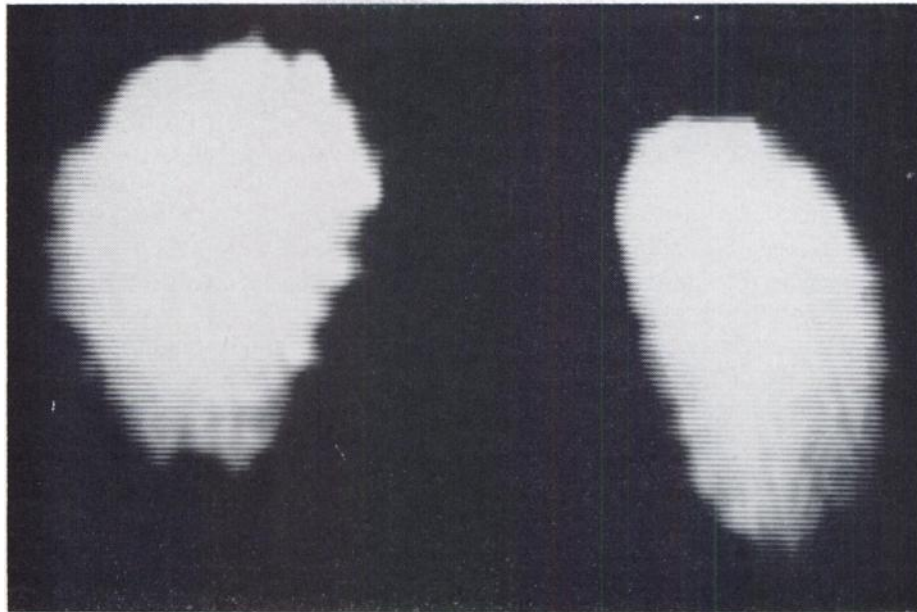

**Fig. 8. Photoscan of normal kidneys.**

suitable enhancing and background cut-off circuits before being used to modulate the intensity of the oscilloscope beam. By this means a scan picture is produced on the oscilloscope screen when the contrast etc. is adjusted to the desired level.

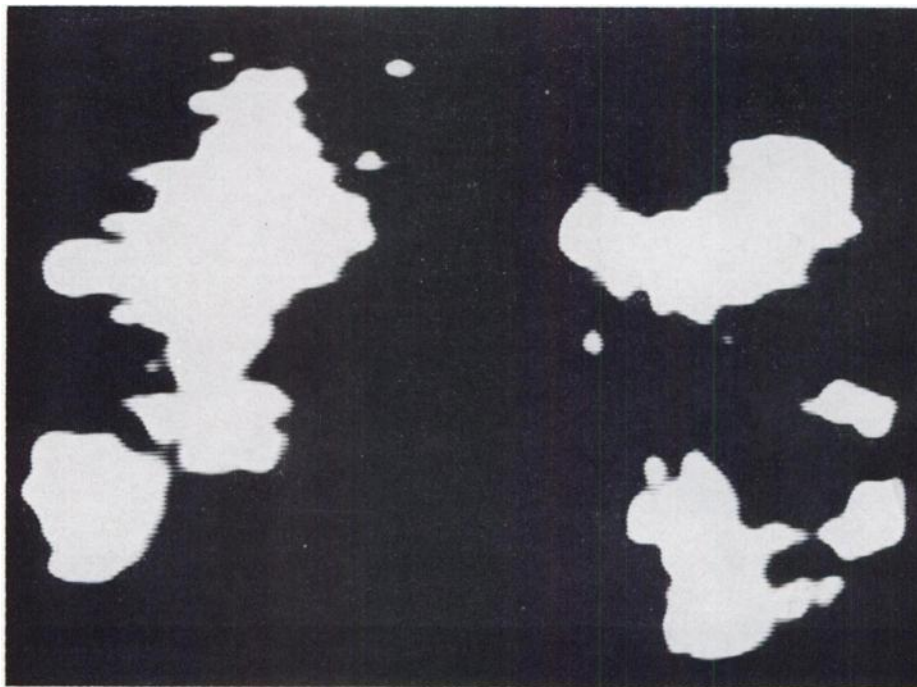

**Fig. 9. Photoscan of polycystic kidneys.**

The contrast enhancement and cut-off circuit is a transistorized unit built to the design of Mr. R. Cobbold of the Electrical Engineering Department, University of Saskatchewan. The circuit consists of two stores into which the pulses are fed sequentially under the control of a clock pulse. These stores give a D.C. output proportional to the counts received in the pre-set sampling time. This D.C. voltage is applied to a modulator so that an amplitude-modulated signal proportional to the count rate is applied to the grid of the cathode-ray tube of the oscilloscope. Controls in the amplifier-modulator stage allow contrast enhancement and background cut-off to be accomplished.

The reproduced scan formed on the cathode-ray screen is photographed with a press camera using a Polaroid film-back and by this means the scan picture is available about two minutes after the scan has been completed. Also, since the scan information is stored on magnetic tape it is possible to replay the information and produce further scan pictures with varying degrees of background cut-off and contrast enhancement.

The polaroid transparency may be displayed on a T. V. set by inserting it

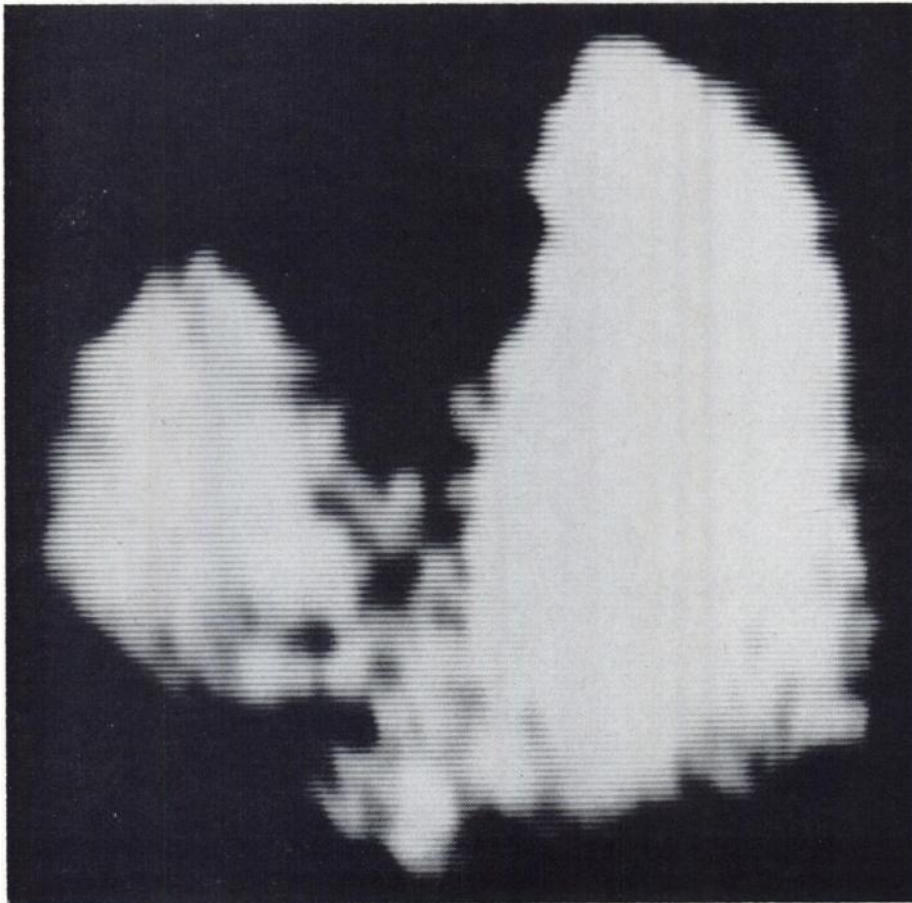

Fig. 10. Photostatic of a horseshoe kidney.

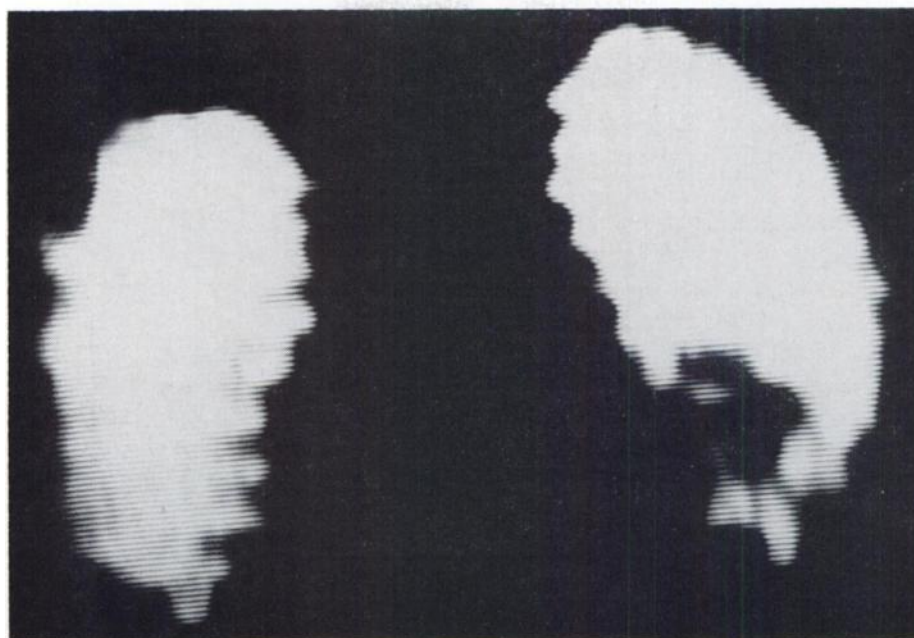

Fig. 11. Photostatic of kidneys showing an area of no uptake in the lower pole of the left kidney. This later proved to be a cyst measuring 2½ cm. in diameter.

into a flying spot scanner or "T. V. Analyst" which is connected to the video stage of the T. V. set. This display of the scan brings it back to life size so that measurements may be made using the oscilloscope graticule scale which represents a 3 cm × 3 cm grid on the patient. The television display also allows the brightness and contrast to be adjusted so that areas of slightly different density which were not readily visible now become emphasized and an assessment of the scan may be facilitated.

A paper chart recorder is also used to record area scans as well as longitu-

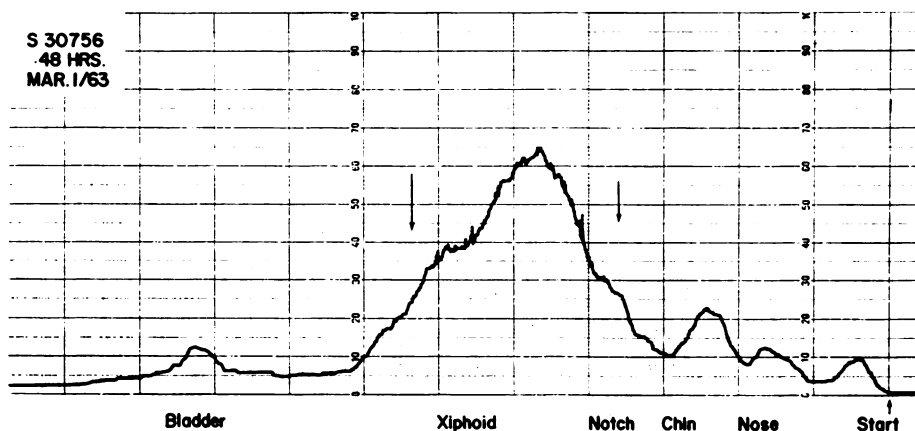
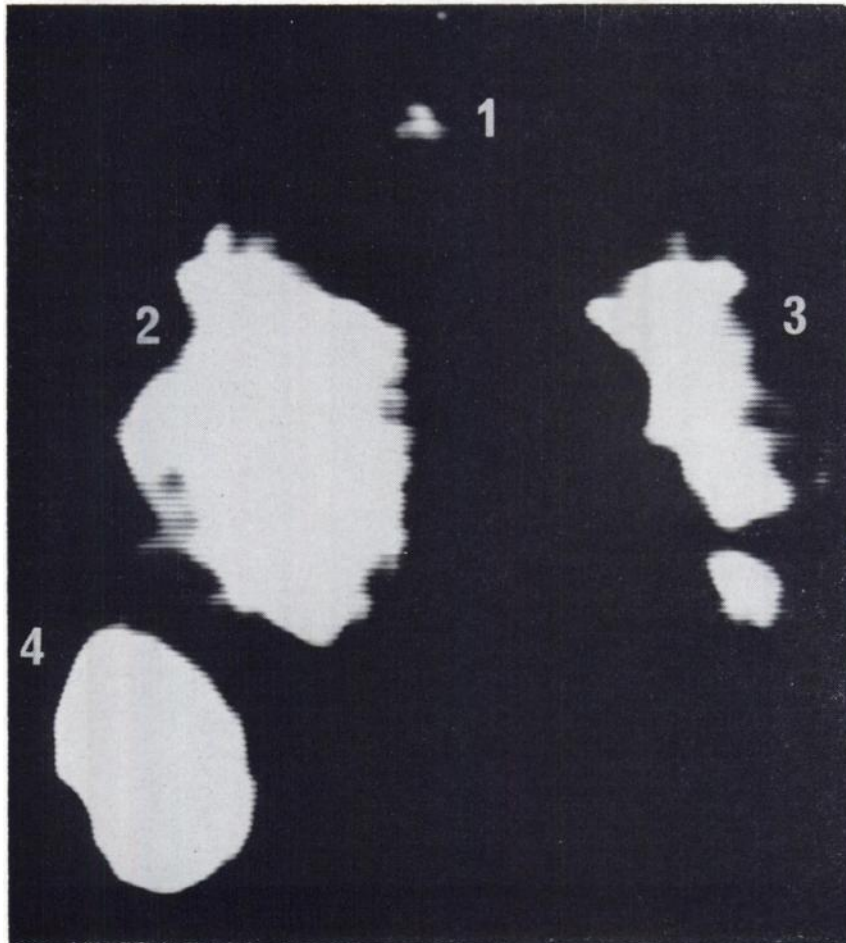

Fig. 12. Longitudinal or profile scan of a patient with multiple thyroid metastases in the chest.

nal scans. This record gives one a sectional view of the count rate variation in each line of the scan and in some cases has proved most useful in indicating areas of minor variation or, as in two kidney scans, areas of functioning tissue where none were detectable on the initial scan but were made visible on replay of the tape. In the case of longitudinal scans with the wide slit collimator the paper chart recorder gives the variation in count rate down the length of the body as the patient moves in one smooth continuous movement below the detector.

#### CLINICAL EVALUATION

The Total Body Scanner was installed in October, 1962, and in the first seven months of operation some 250 scans have been performed. Attention has been focused on liver, kidney, thyroid, longitudinal and pancreas scans.



**Fig. 13.** Photoscan of the chest area of the patient whose profile scan appears in Fig. 12. This scan shows extensive involvement of the lungs (2 and 3) and liver (4) with another small area just visible at the sternal notch. (1).

It is worthwhile at this time to present some examples of scans which have been produced together with the clinical observations. Figure 4 is a dot-scan of a thyroid and indicates the low background level of the detector. Patients for liver scans have  $3\mu\text{c}$ /kilo body weight of  $\text{I}^{131}$  labelled Rose Bengal injected intravenously 20 minutes prior to the scan. Figure 5 is a photo-scan of a normal liver in which the 4th intercostal space is indicated by the arrow. Figure 6 shows two photo-scans of the same patient who had a polycystic liver, the difference between the two pictures being obtained by variation of the controls of the T. V. set. Figure 7 is a photoscan of a liver which has many metastatic deposits from a cancer of the lung. For kidney scans the patients receive  $150\mu\text{c}$  of  $\text{Hg}^{203}$  labelled Neohydrin 1 hour prior to the scan. Figure 8, 9 and 10 are kidney scans showing respectively, normal kidneys, polycystic kidneys, and a horseshoe kidney and Figure 11 indicates the localization of a cyst which was found, on surgery, to be  $2\frac{1}{2}$  cm in diameter in the lower pole of the left kidney.

A longitudinal or profile scan of a patient with multiple metastases from cancer of the thyroid is shown in Figure 12. The scan was made 48 hours after administration of a tracer dose of 500 microcuries of  $\text{I}^{131}$ . The increase in activity in the region of the lungs and liver indicated that a more careful examination of this region should be done and the subsequent photoscan is shown in Figure 13. Figure 13 is the photoscan of the area between the two arrows shown in Figure 12. This scan shows extensive involvement in the patient's lungs (2 and 3 in the scan) and liver (4), particularly in the right lung. Uptake of the iodine in a small retrosternal mass (1) is also indicated in the scan.

#### SUMMARY

A description is given of a radio-isotope scanner which employs a  $5\frac{1}{4}$ " dia.  $\times$  4" deep NaI crystal as the primary detector in conjunction with various types of collimators. The scan is displayed on the face of a cathode ray oscilloscope and recorded on a Polaroid transparency. A magnetic tape recording is made to ensure that no scan information is inadvertently lost, but is stored for later reference. The transparency of the scan may be displayed at life size with varying levels of intensity on a television screen, so that minor variations of count rate may be emphasized to enhance areas of low uptake.

#### REFERENCES

1. BROWNELL, G. L.: Theory of Radioisotope Scanning. *Int. Jr. App. Rad. and Isotopes* 3, 181, 1958.
2. CRADDOCK, T. D., and FEDORUK, S. O.: A Study of Collimators for Use in Radio-isotope Scanning Techniques, *Jr. Can. Assoc. Radiologists* XIII, 1962.