

TECHNICAL NOTE

An Adjustable Zoom-Mode Gain Control for Computerized Gamma-Camera Systems

Robert L. Richardson and F. Deaver Thomas

SUNY Upstate Medical Center, Syracuse, New York

Many nuclear medicine departments use a digital computer to process scintillation-camera images. For optimal use of the computer, there should be a means to amplify the position signals of each scintillation event by an appropriate amount before their conversion to digital form. What is needed is a series of calibrated gains from which the best value may be chosen. Many systems now in use do not provide such a selection. The circuitry described here provides an inexpensive solution to this problem. It may be inserted between the camera and the computer's analog-to-digital converters to provide the desired amplification. No internal modification of the computer or the camera is required.

J Nucl Med 21: 790-792, 1980

Many nuclear medicine departments use a digital computer to process scintillation-camera images. The camera produces analog X and Y position signals for each scintillation it detects. These signals are converted to a digital form and then applied to the computer input. For optimal use of the computer, there should be a means to amplify the analog signals by an appropriate amount before their conversion to digital form. The system presented here allows the operator to select any one of five calibrated gains for amplifying the analog signals. Its operation will be explained by describing its application to a laboratory computer.*

In this computer system, the analog-to-digital conversions are performed by an ADC unit that also provides selectable amounts of signal amplification. A block diagram of a typical system is shown in Fig. 1.

The computer that receives the digital position signals uses them to place counts at the appropriate positions in a 128- by 128-element field matrix. (In some cases matrices with fewer elements are used.) Amplification of the signals in the A/D converters increases the image size in the matrix. Since the matrix has a fixed number of elements, amplification of the position signals reduces the area of the camera crystal whose data are within the matrix boundaries. In other words, as the image is magnified, the regions near the edge of the camera crystal move outside the computer matrix and are lost.

For optimal data processing and picture resolution, the image

of the target organ should be as large as possible without extending beyond the edge of the matrix. Since organ size varies over a large range, this requirement can be met only by having a relatively large range of adjustment for the gains in the A/D converters.

In the ADC units of the Gamma 11 there are two cascaded stages of amplification (A1 and A2) ahead of the actual A/D conversion. The first stage (A1) has two modes of operation selectable by a front-panel switch. In one mode it has a fixed gain of unity. In the other its gain may be varied between 0.5 and 5.0 using a front-panel control knob.

The second stage of amplification, A2, also has two modes of operation. In the REGULAR mode ("MODE 2") the gain is usually set internally near the lower end of its range of 0.25 to 2.0. In the ZOOM mode ("MODE 1") the gain is normally set near the upper end of that range. REGULAR or ZOOM mode selection

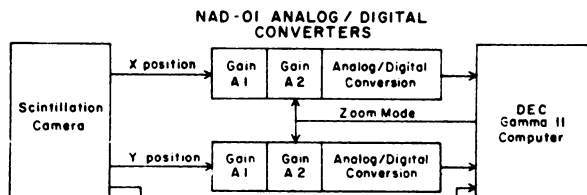

BLOCK DIAGRAM OF SCINTILLATION CAMERA/COMPUTER INTERFACE

FIG. 1. Block diagram of interface between scintillation camera and computer.

Received Jan. 22, 1980; revision accepted April 2, 1980.

For reprints contact: Robert L. Richardson, PhD, Div. of Nuclear Medicine, SUNY Upstate Medical Ctr., Syracuse, NY 13210.

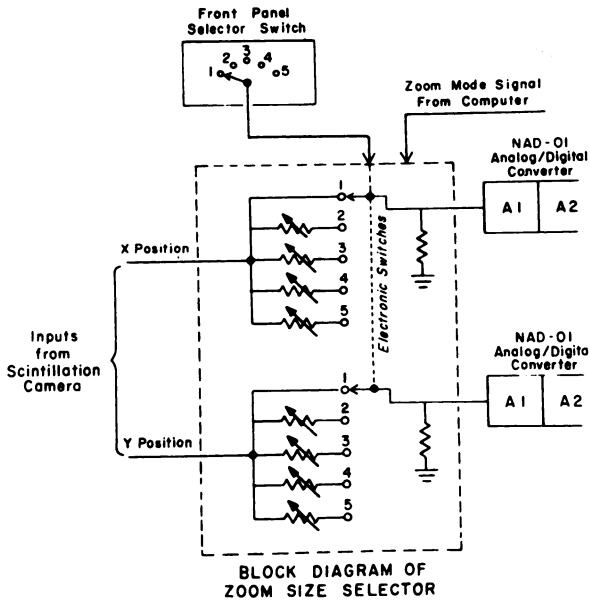
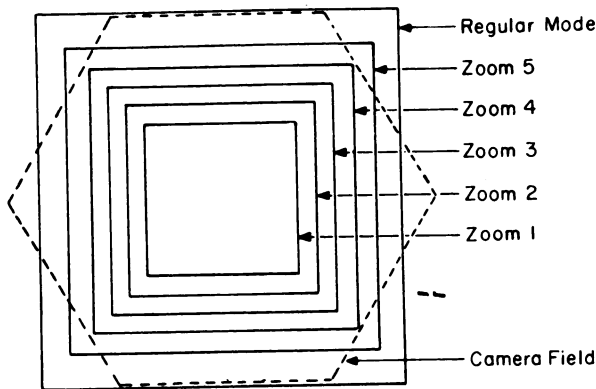

FIG. 2. Block diagram of ZOOM-mode selector.

is under computer program control. The computer is therefore able to select only two input gains, and this does not ordinarily allow for optimum use of its image matrix. Of course, there is also the front-panel variable gain mode for the first stage of amplification but its use reduces reliability since one cannot be sure that the X and Y axis amplifiers have identical gain. Furthermore, the use of continuously variable front-panel controls produces images whose minification is not precisely known.

What is needed is a system offering gain that can be changed in small calibrated steps. The operator may then choose the step that provides optimum use of the image matrix. To accomplish this the ZOOM Size Selector, shown in Fig. 2, was designed. This circuitry, which is placed just ahead of the A/D converters, consists of two five-position attenuators that are automatically switched into the circuit when the system operates in the ZOOM mode. The various attenuator steps are selected by a front-panel switch. Switch Position 1 provides no attenuation and therefore produces maximum image magnification. This maximum is determined by the internal adjustment of the ZOOM-mode gain of A2 and in



AREA COVERED BY COMPUTER MATRIX FOR VARIOUS MODES OF OPERATION

FIG. 3. Area covered by computer matrix for various modes of operation.

TABLE 1. DIMENSIONS, IN INCHES, OF CAMERA FIELD AS LIMITED BY COMPUTER MATRIX FOR VARIOUS MODES OF OPERATION

| System operating mode | Standard-field camera | Large-field camera |
|------------------------|-----------------------|--------------------|
| ZOOM mode | | |
| switch position | | |
| 1 | 4 X 4 | 6 X 6 |
| 2 | 5 X 5 | 7.5 X 7.5 |
| 3 | 6 X 6 | 9 X 9 |
| 4 | 7 X 7 | 10.5 X 10.5 |
| 5 | 8 X 8 | 12 X 12 |
| REGULAR mode | 9.75 X 9.75 | 14.5 X 14.5 |

practice is set at the maximum available (2.0). Less image magnification is obtained by selecting one of the other electronic switch positions.

The adjustable resistors associated with switch Positions 2-5 are set during a calibration run to have successively increasing values. This produces increasing attenuation and therefore decreasing image magnification.

Note that the electronic switches are held in Position 1 whenever the system is in the REGULAR mode. The Size Selector, therefore, has no effect when the system operates in this mode.

System gain in the REGULAR mode is normally adjusted so that the camera's extrinsic field just fits inside the computer matrix. That is, the flats of the hexagonal field fill the matrix, with the corners just outside it. For ZOOM-mode operation, the increased system gain causes the computer matrix to cover a square area that lies inside the camera field (the greater the gain the smaller the square). After some experimentation we find that system gains for the ZOOM mode should be set to magnify portions of the camera field, as shown in Fig. 3, and having the dimensions given in Table 1.

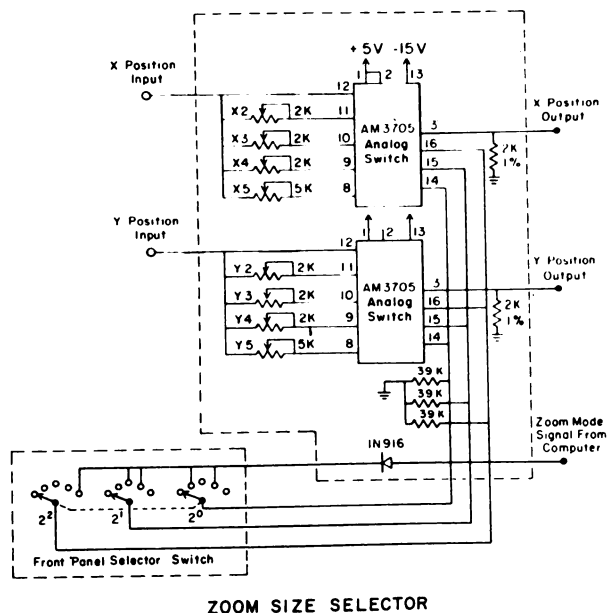

FIG. 4. Schematic diagram of ZOOM-mode selector.

Figure 4 shows the schematic diagram of the ZOOM size-selector circuit. The type AM3705 analog switches[†] actually have eight input positions. If desired, one could add three more stages of attenuation, thereby reducing the size of the steps between the various switch positions. In our work we found that the five steps shown in the figure provided an adequate amount of selectivity. The Front Panel Selector switch is energized by a +5-volt signal from the computer when the system is in the ZOOM mode. This signal, which must be brought out from the computer back plane, is used by the switch to produce a digital code that selects the desired analog switch positions. When the computer is in the REGULAR mode, the signal from the computer drops to zero volts. This causes the No. 1 position of the analog switches to be selected regardless of the setting of the front-panel selector. If this system is used with a computer that does not provide a +5-volt signal when in the ZOOM mode, the signal could be obtained manually from a second switch placed on the front panel and connected to the +5-volt supply.

The circuit design presented here will operate well with computing systems having input impedances on the position-signal lines that are large compared with 2,000 ohms. This is the normal situation. If smaller input impedances exist, the adjustment potentiometers of the analog switches must have proportionately smaller values.

The advantage of the ZOOM Size Selector is that it provides five selectable values of image magnification when the system operates in the ZOOM mode while having no effect on system operation in the REGULAR mode. Each value of magnification can be precisely set and the availability of five different values means that the computer matrix may be used in close to an optimal way for a large range of organ sizes. This is particularly helpful for cardiac studies, since the field size in ZOOM mode can be adjusted during setup (i.e., patient monitor program) to maximize the heart's image from the smallest pediatric patients (4- by 4-in. field) to adults with massive cardiomegaly.

The circuitry described here may be used with any combination of scintillation camera and computer. It is inserted between the camera and the computer's analog-to-digital converters. No internal modification of the computer or the camera is required. The total parts cost for fabricating this device was less than \$35.00, since the +5-volt and -15-volt supplies already in the computer were used as power sources.

FOOTNOTES

* Gamma 11 computer with NC-11 interface, Digital Equipment Corp.

† National Semiconductor.

**CENTRAL CHAPTER
SOCIETY OF NUCLEAR MEDICINE
FALL MEETING**

October 4-5, 1980

Playboy Club

Lake Geneva, Wisconsin

The Central Chapter of the Society of Nuclear Medicine announces its Fall Meeting to be held October 4 and 5, 1980 at the Playboy Club in Lake Geneva, Wisconsin.

This one and a half day session on "Advances in Cardiovascular Nuclear Medicine" will feature sections on ventricular function studies, myocardial imaging, tomographic imaging of the heart, new data processing techniques, sudden cardiac death, and pediatric nuclear cardiology. The special guest faculty are William Ashburn and Robert A. Vogel.

The Technologist section will also present a program of special interest to technologists on myocardial imaging.

For further information contact:

Deborah Churan, Executive Director
Central Chapter, SNM
PO Box 160
Crystal Lake, IL 60014