

PRELIMINARY NOTE

Simultaneous Use of Two Radioisotopes by Scanner Plus Analogue Computer Coupling¹

Richard P. Spencer

New Haven, Conn.

A pressing and recurrent difficulty in nuclear medicine has been the inability to scan one radioisotope in the presence of a second that has a gamma emission of partially overlapping energy. If this problem could be solved, it should also be possible to scan two radioisotopes simultaneously. A possible solution is presented here by means of coupling an analogue computer to the radioisotope scanner.

THEORY

The output of the rate meter from radioisotope scanning device can be led directly into an analogue computer. These studies utilized a Picker Magnascanner; the analogue computer was a PACE TR-20 (Electronic Associates, Inc.). Signals from the scanning crystal, three inch NaI, thallium-activated, and photomultiplier were fed into two gamma ray pulse height analyzers, each of which was attached to a count rate meter (Fig. 1a). The outputs of the count rate meters were brought into the analogue computer.

Using a previously employed nomenclature¹ one of the pulse height analyzers is referred to as the upper channel (U) and the other as the lower channel (L). The voltage from the count rate meter attached to U is due to radioisotope B and a contribution from radioisotope D. Voltage from the count rate meter attached to L is due to radioisotope D and a contribution from B. We have the relationships:

$$U = B + cD \quad (1)$$

$$L = aB + D \quad (2)$$

where a and c are constants to be determined experimentally. We then solve for B and D in the following manner.

$$B = (U - cL) / (1-ca) \quad (3)$$

$$D = L - aB \quad (4)$$

¹Supported by Grants CA 6519 and HD 0411 from the U. S. Public Health Service.

These forms were chosen for convenience in using the analogue computer. The denominator of equation (3) is a constant and can be set on a potentiometer. Once B is found on the computer, D follows since L is known, and the term a in equation (4) is constant. Patching of the analogue computer is shown in Fig. 1b (Z_L and Z_U represent background noise that can be subtracted out by the

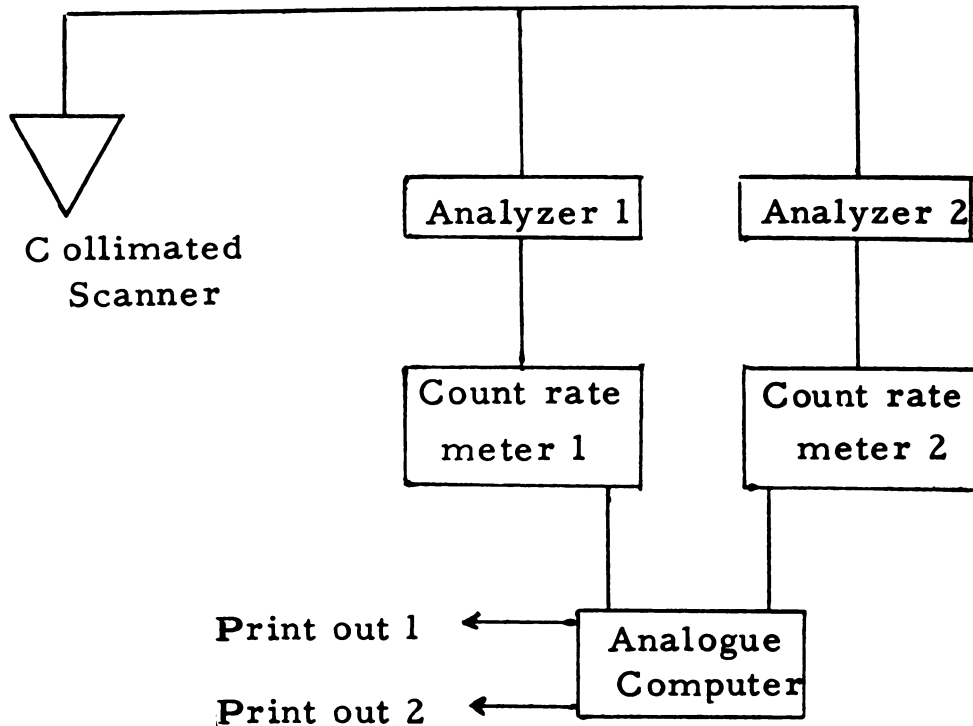

Fig. 1 (a) Block diagram of scanner and computer.

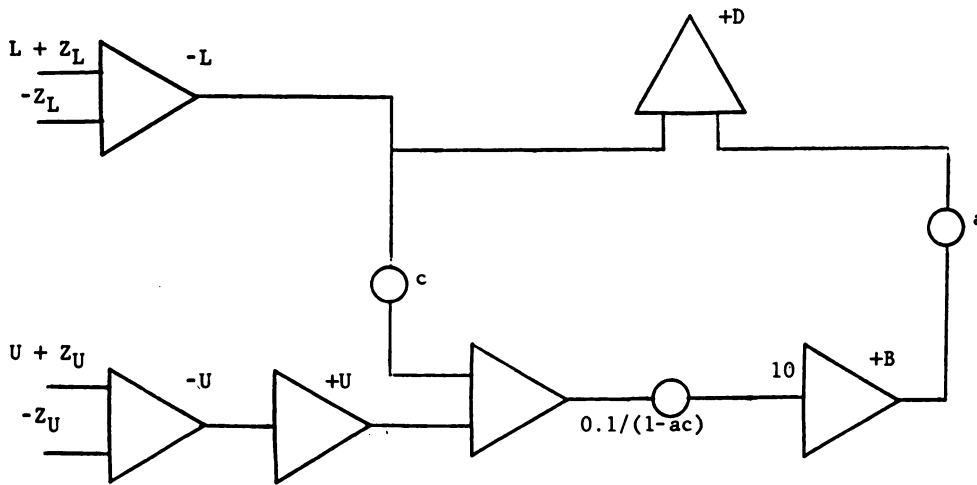

Fig. 1 (b) Analogue computer circuit diagram.

computer). Conventional symbols are employed. A potentiometer is indicated by a circle, and an amplifier with internal feedback is depicted by a triangle. This simple circuitry immediately solves the difficulty mentioned in the first paragraph. That is, an organ with a residual of one radioisotope can be scanned for a second radioisotope, since there is continual correction for overlap of their energy spectra. In addition, the system is "on line" and available for inspection. Further, two radioisotopes, with differing gamma ray energies, located in the same body region can be scanned simultaneously.

For example, we have begun studies on the simultaneous distribution of iodine radioisotopes, as well as of ^{51}Cr -tagged erythrocytes and ^{59}Fe in the liver and spleen. Computer settings are particularly easy with this latter pair of radioisotopes since there is no overlap of the chromium emission at the peak of the iron 1.1 MeV gamma emission, although the scanning probe has to be wrapped with additional lead to reduce penetration of the Fe x-rays into the crystal. With the window settings used for the chromium emission (0.27 to 0.37 MeV) on the Picker Magnascanner, there is a cross-over of about 33 per cent from the Fe counts. The two outputs of the analogue computer are then used to drive the photorecorders in two separate Picker Magnascanners. It should be apparent that such a scheme of scanner plus analogue computer coupling will be most successful when high counts are present. First, the count rate meter in the scanner can be used with a short time constant so that there is a rapid response to changing activities. Second, with higher count rates, there is increased statistical accuracy in subtracting the value of one signal from another. The computer can be arranged to subtract out not only *room* background, but also that set according to some chosen parameter, such as the value in the blood stream as determined by monitoring a limb or the quantity in a neighboring structure.

The ability to scan one radioisotope in the presence of a second, or to scan two radioisotopes simultaneously, should have a number of clinical applications. Details of converting commercial scanners for such purposes, and other applications of analogue computer plus scanner coupling, will be described in later papers.

SUMMARY

By direct coupling of a radioisotope scanner to an analogue computer, it is possible to scan one radioisotope in the presence of a second, or to scan two radioisotopes simultaneously.

REFERENCE

1. SPENCER, R. P.; SEIFE, B.: Channel ratio in the determination of two gamma-emitting radioisotopes. *J. Nuclear Med.* 5:562-564, 1964.