

---

# Variation of Gamma Camera Photographic Image Density with Count Rate

Robert L. Richardson and Charles E. Duxbury

*Department of Radiology, Division of Radiological Sciences, SUNY Upstate Medical Center, Syracuse, New York*

In recent years there has been a gradual shift in gamma camera image recording toward the use of transparency films. When this occurs one encounters the intermittency effect. This effect causes the image density to increase as the count rate increases. In addition, density may also increase because the light output per count from the cathode ray tube also increases as the count rate increases. If these effects are not taken into account, images obtained at low count rates may be too light and those obtained at high count rates may be too dark. This paper discusses these phenomena and presents experimental data that shows how image density varies with respect to count rate for several commonly used films.

J Nucl Med 27:128-131, 1986

---

In recent years there has been a gradual shift in gamma camera image recording away from the use of Polaroid film. In its place many hospitals are using transparency film produced by one of the several major manufacturers. The utilization of such film reduces costs and, when used with a multi-imaging system, makes it possible to place many images on a single sheet—a definite convenience.

In the process of shifting from Polaroid to transparency film however, the user encounters the “Intermittency Effect.” This effect, which is not well known to many people in the field, is a form of reciprocity law failure. Investigated by Maerker in 1953 (1), it is manifested in photographic applications where the recorded image is obtained from interrupted exposures. The dots that produce gamma camera images constitute such an exposure.

In Fig. 1, the result of the intermittency phenomenon is shown. Both images contain 1,000,000 counts and all system parameters were the same except that the count rate for image (1A) was 531,000 cpm while that for (1B) was 12,000 cpm. It will be noted that the higher count rate produced a significantly more dense image.

Historically, gamma camera images have been recorded on Polaroid film which does not appear to suffer from intermittency limitations in any measurable way. Still, practitioners have always had problems with image brightness and the triple-lens camera has been widely used to overcome this difficulty. When the user shifts to transparency film, intermittency effect variations are added to those already present in clinical imaging.

In his work, Maerker found that when film was exposed to a series of periodic flashes of light, the resulting image density varied inversely with respect to the time between the flashes. This effect, which was explained using the contemporary theory of photochemical reactions, was found to take place over a limited frequency range. It produced a relatively small percentage change in the image density for most of the films that were tested.

Maerker used a motor-driven opaque disk with a variable width slit cut into it to obtain the desired series of light flashes. The disk was placed between the light source and the film. By changing the rotational velocity of the disk and making a corresponding change in the slit width, he was able to change the time between the flashes while not effecting the length of the flashes themselves. Unfortunately, the films which he tested are no longer used. We therefore decided to repeat his experiments using presently available film. Additionally, it was decided that the light flashes should be ob-

---

Received Apr. 8, 1985; revision accepted Aug. 30, 1985.

For reprints contact: Robert L. Richardson, PhD, Div. of Nuclear Medicine, Upstate Medical Center, 750 E. Adams St., Syracuse, NY 13210.

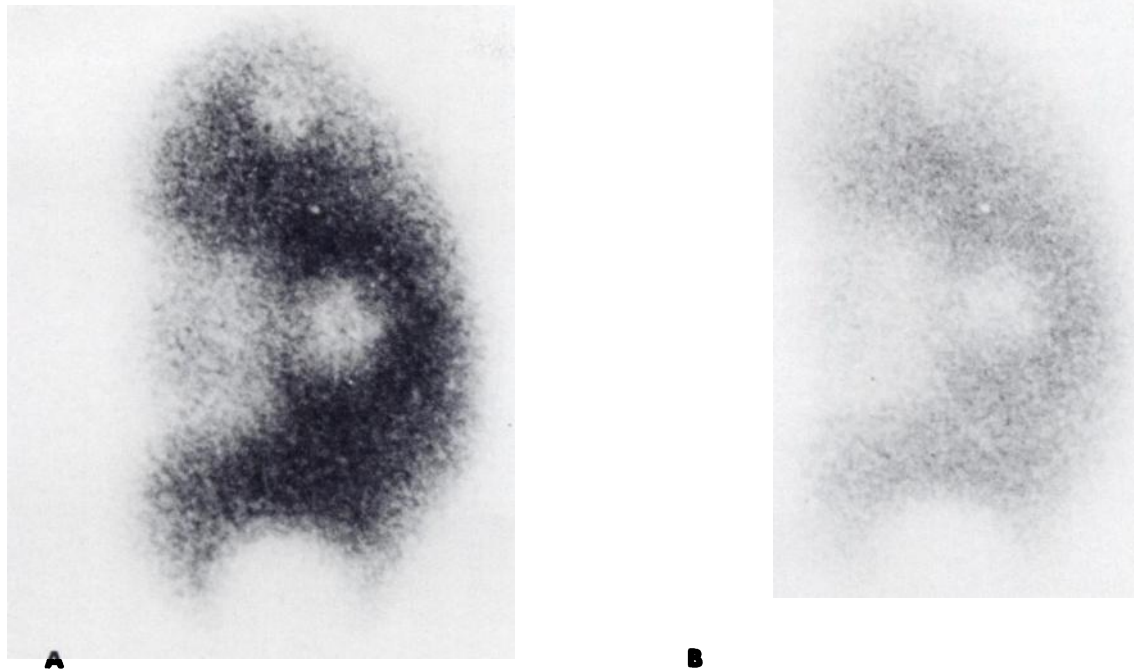

**FIGURE 1**  
 Images of kidney phantom showing Intermittency Effect. Both images contain 1 million counts. Count rate for image A was 531,000 cpm, while that for image B was 12,000 cpm

tained from a cathode ray tube (CRT) since this is the light source utilized in nuclear medicine instrumentation.

**METHODS AND RESULTS**

A Model 100-20 Ultimat\* was modified and used as the major part of the experimental system whose block diagram is shown in Fig. 2. The deflection signals were removed from the Ultimat cathode-ray tube so that all dots were displayed at the same point in the center of the tube. The Ultimat intensifying pulses were obtained from a stable pulse source whose frequency could be adjusted. These pulses were fed through

an electronic switch and then to the imager. They were also fed to the counter which controlled the electronic switch. The counter turned the switch off after a previously selected number of pulses had been applied to the display. By varying the frequency of the oscillator, the pulse spacing could be controlled. The pulse length was 800 nsec.

The dots which are displayed on the CRT are normally focused on the Ultimat film. For these experiments, in addition to the normal lens system, a magnifying lens was added between the CRT and the film plane. This caused the recorded image to be spread out such that the image of each dot had a diameter of ~2 mm on the film. This enlarged dot size was necessary so that the recorded image density could be measured on a Macbeth TD-102 Densitometer.

In the course of the experiment it was found that great care had to be taken to insure that variations in film or processor characteristics did not affect the film density that was obtained. All of the film of a particular type was taken from the same box and was developed at the same time in a highly temperature-controlled processor. The time interval between exposure and processing varied between one and three hours. The Ultimat was turned on 1 hr before any exposures were made and standard film cassettes were used.

Each exposure consisted of 24 flashes (dots) on the CRT. The flashes were produced by equally spaced intensifying pulses whose interpulse interval was varied from 1 msec to 100 sec. The results for Eastman Kodak type NMB and NMC and Du Pont type MRF31 and MRF32 films are shown in Fig. 3.

The density variation found in these experiments exceeded that obtained by Maerker in both magnitude of density

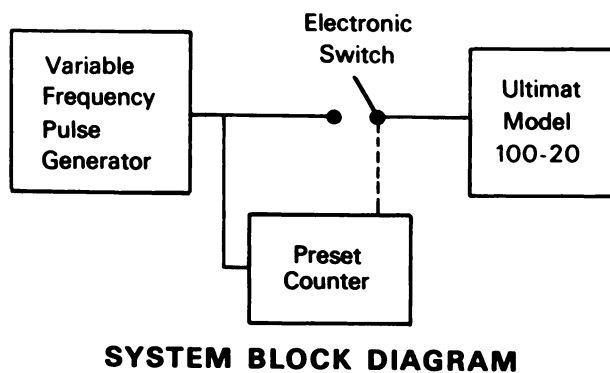

**FIGURE 2**  
 Block diagram of experimental system

change and pulse spacing range. One possible explanation for this is that the light output of the cathode-ray tube phosphor increased as the pulse spacing decreased. If this occurs it would explain part of the density increase and would affect clinical images in the same way as the test films. To investigate this possibility, a 3-in. photomultiplier tube was mounted above the Ultimat lens system in place of the film cassette. The tube output, which is proportional to the light produced by the CRT, was inverted and displayed on an oscilloscope. The resulting images were photographed on Polaroid film. Sequences of eight pulses with spacings from 20  $\mu$ sec to 10 sec were used. A typical oscilloscope output waveform is shown in Fig. 4A. It can be seen that there is a pulse to pulse increase in light output from the cathode-ray tube over part of the interval.

In a second set of experiments measuring the CRT light output as a function of pulse spacing, each displayed dot was given a small X-axis displacement so that a different area of the phosphor was used for each flash. In this case there was no intensity buildup as shown in Fig. 4B.

## RESULTS AND DISCUSSION

### Film Density Variations

The variation in film density as a function of pulse spacing is shown in Fig. 3. It will be noticed that the minimum variation in density is 2:1 and that the maximum is over 3:1. These results far exceed the range obtained by Maerker who found very little change in density for pulse spacings greater than 5 sec or less than 0.5 sec. The film densities covered by the curves are essentially the same as those used in nuclear medicine imaging.

For pulse spacings less than those shown in the figure the curves tend to flatten and then to drop such that the film densities for pulse spacings of 10  $\mu$ sec are about equal to those obtained in the range from 0.02 to 0.1 sec. This data was not shown in the figure because it is far outside the range used in nuclear medicine applications.

The curves shown in Fig. 3 have no absolute meaning since they will move up and down as the imager intensity control is

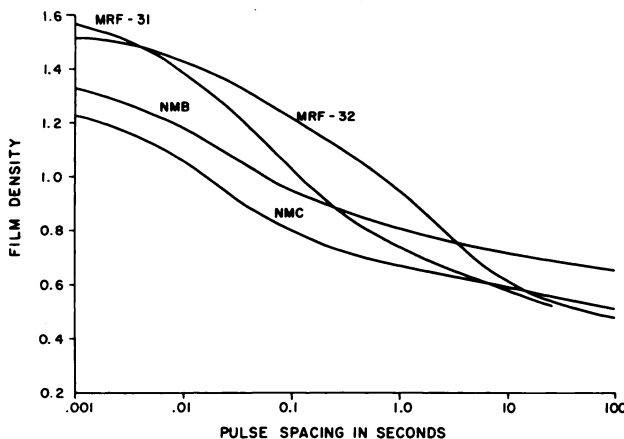

**FIGURE 3**  
Film density vs. intensifying pulse spacing for four commonly used nuclear medicine films

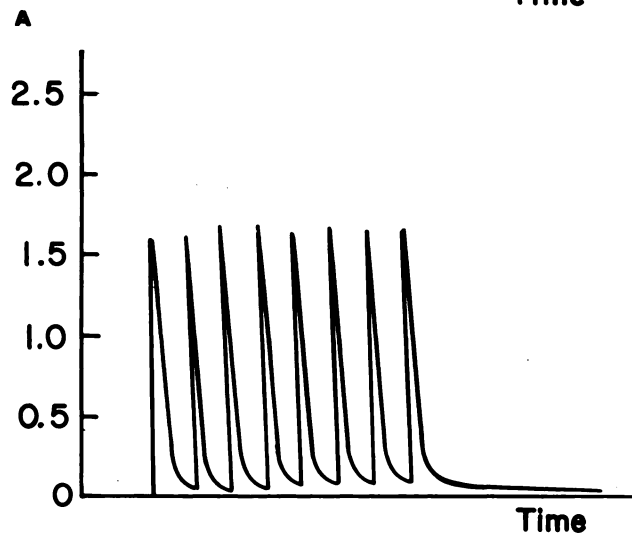
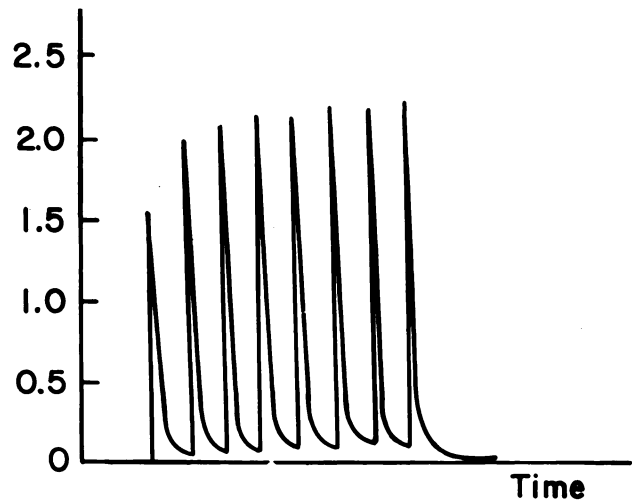

**FIGURE 4**  
Cathode-ray tube light output vs. time for intensifying pulse spacing of 80  $\mu$ sec. A: All dots in same position on tube face. B: Each dot at different position on CRT phosphor

increased or decreased. They also depend on the characteristics of the film and the means of development. The data for all of the curves were taken at the same Ultimat intensity setting, however.

One can obtain useful measures of film density variation by determining the maximum and average slope of each curve. These slopes are presented in Table 1. It can be seen that the Du Pont films display more variation than the Kodak films.

### Cathode Ray Tube Light Output Measurements

Figure 4A shows the sort of pulse to pulse buildup in CRT light output that occurs when the intensifying pulses are closely spaced. The buildup occurs for the first four pulses after which a saturation value is obtained. This value is 40% higher than the light output of the first pulse. It should be noted that the baseline shows small pulse to pulse increases also. This is due to the light output decay characteristic of the CRT phosphor.

**TABLE 1**  
Average and Maximum Slope of Film Density Curves  
Shown in Fig. 3 in Density Units per Decade

Film type	Average slope	Maximum slope
Kodak NMB	0.15	0.25
Kodak NMC	0.15	0.29
Du Pont MRF31	0.24	0.39
Du Pont MRF32	0.23	0.36

For pulse spacings greater than 0.02 sec, no CRT light buildup was observed. As one reduces the spacing below this value, however, the light output gradually increases such that at a spacing of 0.001 sec (the minimum value shown on the curves of Fig. 3) the saturation light output is 11% above that produced by the first pulse in the train. When the pulse spacing is further reduced, the saturation light output continues to increase reaching a value that is 300% above the low frequency value for a spacing of 10  $\mu$ sec. In this region, however, the film density curve is actually flattening and then decreasing as described above. No explanation of this phenomenon has been found despite the fact that many possibilities have been investigated.

When the cathode-ray tube dot is moved such that each dot occurs at a different point on the phosphor, no output light buildup is observed as shown in Fig. 4B. Each pulse has an amplitude similar to the first pulse of Fig. 4A. The small random variation of pulse amplitudes is due to variations of phosphor light output efficiency at the various points on the face of the CRT. This sort of performance was observed at pulse spacings from 10  $\mu$ sec to 10 sec.

The increase in CRT light output that occurs when successive dots occur close in time and at the same X-Y position, must be due to a nonlinear light output versus current input characteristic of the CRT phosphor. The film density increases at the higher count rates shown in Fig. 3 are therefore due to two phenomena. The film produces part of the increase due to the intermittency effect and the display system produces increased light output per dot as the dot spacing in time becomes less.

The sort of image density variation that is described here has not been observed on Polaroid film. This is probably due to the fact that this film does not show intermittency effects and that few nuclear medicine images are made under conditions where significant phosphor light output increases occur.

## DISCUSSION

### Applying Results to Nuclear Medicine Imaging

To use the curves shown in Fig. 3 one needs to know what range of pulse spacings is encountered in nuclear medicine imaging. To determine this, we need to know how often, on the average, a given point on a piece of film receives a flash of light from the CRT. To do this we must know what the CRT spot size is at the point where it is focused on the film. We also need to know the count rate and the image size on the film. Consider the following:

Assume that the image placed on the film covers an

area that is  $\sim 25$  mm square. It therefore has a total area of 625 mm<sup>2</sup>. Assume that the CRT spot size on the film is circular and has a diameter of 0.3 mm (0.012 in.). The corresponding spot area is therefore 0.07 mm<sup>2</sup>. If we assume that the count rate is 300,000 cpm (5,000/sec) and that all parts of the image receive illumination randomly and equally, then each point on the film receives dots at the rate:

$$\text{Average Counts/Second/Image Element} \\ = 5,000/625/0.07 = 0.56/\text{sec or one dot every 1.8 sec.}$$

In practice of course, larger and smaller count rates and image sizes are used so that the effective dot rate will vary over several decades. One therefore operates at points that are located over a large portion of the curves shown in Fig. 3. This tends to produce a relatively large change in image density. Of course such variations can be compensated for by increasing or decreasing the display brightness control as one utilizes lower or higher count rates. The compensation need not be complete but more uniform image densities can be obtained by taking this effect into account. The amount of compensation must be experimentally determined for each imaging system. If these effects are not taken into account, images obtained at low count rates may be too light and those obtained at high count rates may be too dense.

When people using gamma cameras are not aware of the intermittency effect, they may attribute the variations in image density to defective equipment. We are aware of an instance where the service engineer was called to remedy such a situation. After much effort and cost, no improvement was obtained and both the user and service engineer thought that the system was defective.

Like any other equipment, the user of gamma cameras will be able to obtain better results if he understands as fully as possible how the system operates and its limitations.

## FOOTNOTES

\* Technicare Corp., Solon, OH.

## ACKNOWLEDGMENTS

The authors thank Richard W. Arnold, MD, of the Royal Alexandra Hospital, Edmonton, Alberta for his efforts toward starting this investigation.

## REFERENCES

1. Maerker RE: Estimation of the critical T period in latent-image formation by intermittent exposure. *JOSA* 44:625-629; 1954
2. Grossman LW, Van Faimen RJ, Kruger JB, et al: Film reciprocity law failure in scintillation camera imaging. *Radiology* 138:697-700; 1981