

Cassette Videotape Recording of Computer Images

Paul H. Murphy, John A. Burdine, and Carlos C. Martin

*Baylor College of Medicine and Nuclear Medicine Service and Heart Sounds
Laboratory, St. Luke's Episcopal/Texas Children's Hospitals,
and Texas Heart Institute, Houston, Texas*

Direct videotape recording of images from computer display terminals is often not possible because of the nonstandard outputs of these systems. A video-sync mixer is described that permits black-and-white recording on standard 3/4-in. videotape cassettes.

J Nucl Med 19: 852-853, 1978

Electrocardiogram-gated scintiphotos of the cardiac blood pool are valuable in the assessment of global regional and overall left-ventricular contractility. Gated scintigraphy is gaining widespread use in the diagnosis and management of a variety of cardiac diseases.

In recent years ECG-gated blood-pool images have been processed in computers, permitting the generation of multiple frames of lata representing composite images of a typical, complete, cardiac cycle (1,2). For example, if the cardiac cycle is divided into ten equal time segments, and scintigraphic data from many cardiac cycles are accumulated in each of the corresponding frames, then ten composite images of different segments of an average cardiac cycle are constructed. If these data frames are sequentially displayed on the computer terminal with continuous recycling through the whole set, one obtains a movie-like presentation of cardiac blood-pool motion. This type data presentation permits more accurate assessment of overall and regional myocardial wall motion than comparison of two static frames corresponding to end-systole and end-diastole. Movie-mode display of cardiac blood-pool motion in the RAO and LAO projections is adequate for analysis of segmental wall motion for most of the major segments of the left ventricle.

The movie-mode presentation of cardiac blood-pool motion lends itself to data storage and replay from videotape. If the data can be recorded at the computer on standard cassette videotapes, then the cassette tape can be forwarded to the physician for playback at his convenience on a standard cassette videotape player at the time the patient's study is interpreted and an opinion dictated. It was with this scheme in mind that we attempted to record these computer data on videotape cassettes in our institution. We found, however, that because of the nonstandard nature of the computer output, direct recording on cassette tapes from the color monitor* with standard encoders was not possible. This problem created the incentive to design and construct an inexpensive interface to permit the recording of black-and-white images. A block diagram of the system and the schematic diagram of the mixer are shown in Figs. 1 and 2.

In order to generate a suitable video signal it was necessary to construct an interface that would produce a composite video signal with correct luminescence and synchronization voltage levels. The block diagram in Fig. 1 shows the interconnections of the mixer interface. In applications

where the computer has the video outputs in three color signals (red, blue, and green), the software determines which color output carries the luminescence information in the black-and-white mode. For our system the green must be used, but this could be a different color output in other computer systems. The green video and sync signals are obtained from the loop through outputs of the computer monitor.

The standard 3/4-in. U-matic cassette videotape recorder† is connected to the output of the mixer for data recording, but any NTSC type of recorder will work. For playback and monitoring during recording, a standard television monitor is used. Any monitor that has an adjustable horizontal hold control can be used. Any monitor that has an adjustable horizontal hold control can be used.

Details of the circuit and the characteristics of the desired video signal are shown in Fig. 2. The video and sync levels are fixed by the series clamp diodes in both the video-input and sync-input circuits. These signals are then summed at the base of Q₁ and directly coupled to Q₂, an emitter follower. The output impedance of Q₂ is low and set at 75 ohms to match standard television monitors and video cassette recording equipment. All parts are standard and available from most electronic supply houses for under \$50.

The ability to record movie-mode displays of ventricular blood-pool motion on standard cassette videotapes has proven useful in our institution for the routine analysis of these studies, remote from the computer, by the nuclear medicine physicians. This capability makes the study available to the physician at his convenience for interpretation at his usual place of patient report dictation. In addition, it permits exchange of data between laboratories, and also presentations at seminars and conferences without the need for a computer system compatible with the one used to collect data. It also eliminates the problems and time delay of producing 8-mm or 16-mm movies. In our experience, this mode of display and ease of presentation at locations remote from the Nuclear Medicine Department's computer

Received Sept. 29, 1977; revision accepted Dec. 15, 1977.

For reprints contact: Paul H. Murphy, Dept. of Radiology, Section of Nuclear Medicine, Baylor College of Medicine, Houston, TX 77030.

VIDEO TAPE RECORDING SYSTEM

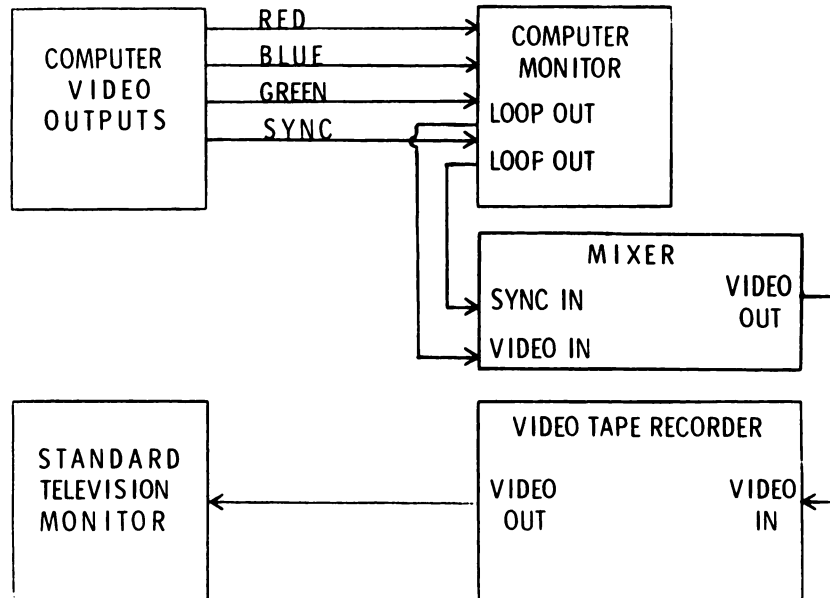

FIG. 1. Block diagram of interconnections between video mixer, videotape recorder and computer monitor.

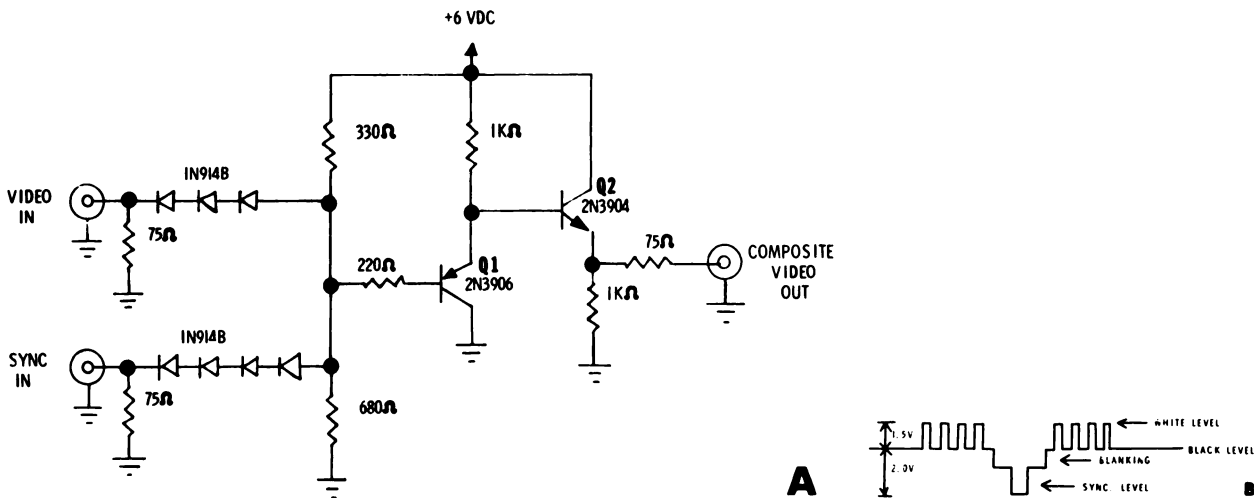

FIG. 2. (A) Circuit diagram for video-sync mixer. (B) Schematic representation of composite video output from video mixer.

have been met with enthusiasm by both the nuclear medicine physicians and referring cardiologists.

FOOTNOTES

* Gamma-11 Computer Systems, Digital Equipment Corporation, Maynard, Mass.
 † Sony Model VO-2800.

REFERENCES

- ALPERT NM, MCKUSICK KA, POHOST GM, et al: Non-invasive nuclear kinocardiography. *J Nucl Med* 15: 1182-1184, 1974
- BACHARACH SL, GREEN MV, BORER JS, et al: A real-time system for multi-image gated cardiac studies. *J Nucl Med* 18: 79-84, 1977