

Direct Recording of Rectilinear Scan Images on 4x5-in. Film

Isaac C. Reese and Fred S. Mishkin

*Martin Luther King, Jr., General Hospital and Charles R. Drew Postgraduate
Medical School, Los Angeles, California*

Rectilinear scans are usually recorded on 14 × 17-in. x-ray film. This is costly both in terms of film and storage space. Using 4 × 5-in. film instead of the larger film will reduce this cost. An Ohio-Nuclear Model 84FD dual-probe 5-in. scanner was converted for the production of scan images directly on 4 × 5-in. film (Kodak SO-79 nuclear medicine film). The smaller images may be viewed directly on a standard x-ray viewbox, or they may be projected if a larger image is desired. The image quality is excellent. This system has replaced the 14 × 17-in. film at our institution.

J Nucl Med 17: 937-938, 1976

Reducing the cost of medical care should be the goal of all persons responsible for health care delivery. In nuclear medicine, a reduction in the costs of film and scan storage would be a step in the right direction. Minification of scintillation images offers economic advantages without discernible loss of diagnostic ability (1,2). While the oscilloscope presentation of data from the Anger camera lends itself to "minified" film formats, data output from the rectilinear scanner has usually been presented on 14 × 17-in. x-ray film regardless of whether the image was minified or life-size.

The output of a rectilinear scanner has been displayed on an oscilloscope and photographed on 35-mm film (1). However, an attempt to accomplish this by connecting a display oscilloscope in parallel with the storage scope of our scanner proved unsatisfactory because of an unstable X-Y signal. We have made a simple relatively cheap modification of the Ohio-Nuclear dual-probe scanner (Solon, Ohio) which gives a stable positioning signal. The output of the scanner is displayed on an oscilloscope and photographed using an open-shuttered 4 × 5-in. scope camera.

MATERIALS AND METHODS

The power supply to the positioning potentiometers of the Ohio-Nuclear scanner was disconnected and replaced by one using two rechargeable nickel-cadmium "D" cells (Fig. 1). These batteries are recharged each weekend and furnish a stable positioning voltage. The X-Y inputs of the Tektronix Model 602 display oscilloscope were connected in parallel with the inputs to the scanner's storage scope. The Z signal for the display scope was obtained from the input to the scanner switch used to select the signal from the lower probe for display (Fig. 2). The signal

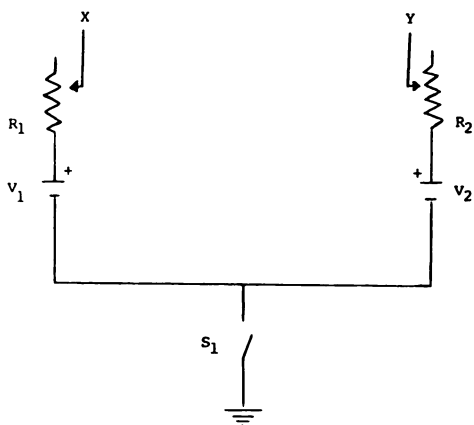

FIG. 1. Power supply: X and Y are leads to positioning potentiometers; R₁ and R₂ are 100-Ω potentiometers; V₁ and V₂ are 1.5-V nickel-cadmium "D" cells; S₁ is plotter switch.

Received March 11, 1976; revision accepted May 24, 1976.

For reprints contact: Isaac C. Reese, Dept. of Radiology, Martin Luther King, Jr., General Hospital, 12021 S. Wilmington Ave., Los Angeles, CA 90059.

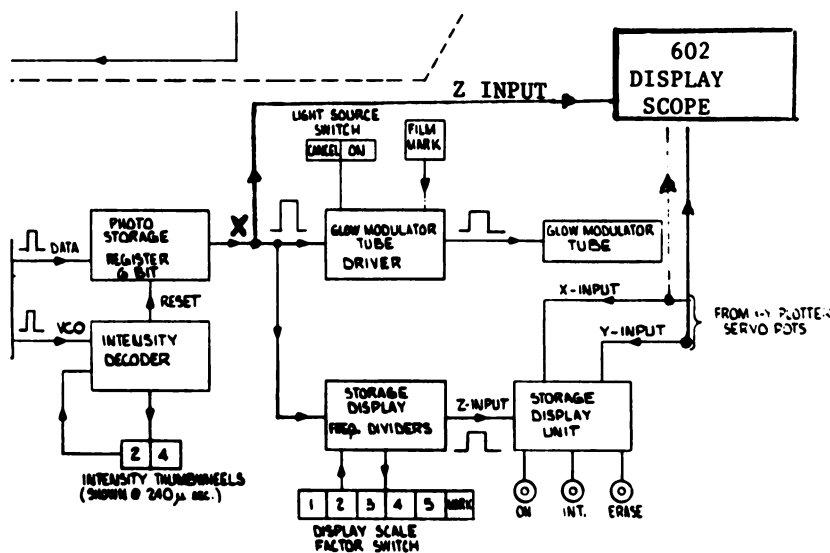

FIG. 2. Block diagram showing connection for Z pulse to display scope.

is thus taken from the output of the photostorage register of the scanner. Therefore, the intensity thumbwheels used to control the photoscan density also control the intensity of the display oscilloscopes. The contrast-enhancement and the tape-playback features of the scanner are also preserved. The oscilloscope output was photographed on Kodak SO-79 nuclear medicine film using a Tektronix C-58 oscilloscope camera with a 4 × 5-in. back.

The film may be processed either through a standard automatic processor for x-ray film or through a smaller automatic processor. The images can be viewed on a standard viewbox or they can be projected with an overhead projector. The scans are stored in specially constructed envelopes, of appropriate size, which are color coded for patient number, examination, and year. Approximately ten such envelopes, each holding five or six films and the typed report, can be filed per inch. Figure 3 shows a 14 × 17-in. image, compared with its 4 × 5-in. counterpart.

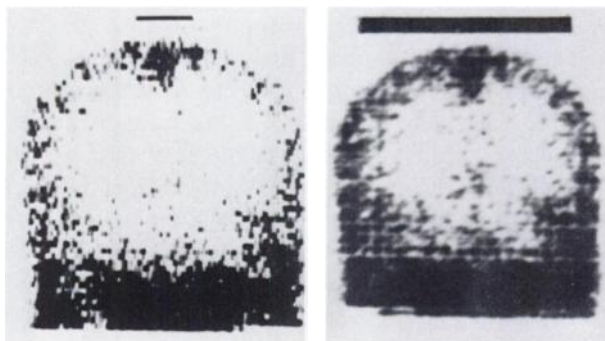

FIG. 3. (Left) Scan image on 14 × 17-in. film; (right) same image data on 4 × 5-in. film. Dimensions of minified image are one-fourth those of regular image (marker on each represents same length). Raster effect is more pronounced on smaller image due to slightly uneven plotter motion and discrepancy between spot size and line spacing.

TABLE 1. COMPONENTS AND COST

No. of units	Description	Cost
2	Oscilloscopes H-P 602	\$1,990.00
2	4 × 5-in. oscilloscope cameras	\$1,210.00
1	Battery charger	9.00
2	D batteries Ni-Cd	3.50
2	Potentiometers and miscellaneous components	20.00
Total cost of parts		\$3,232.50

RESULTS AND DISCUSSION

The images on the 4 × 5-in. film are of excellent diagnostic quality compared to the images on 14 × 17-in. film (Fig. 3). Adding the capacity to produce scans directly on 4 × 5-in. film does not interfere with the traditional use of the scanner for photoscan production on 14 × 17-in. film; in fact, both modes may be used together until one is satisfied with the quality of the 4 × 5-in. images. The savings in film and storage space quickly offset the cost of the modification (Table 1). The saving in film alone (\$0.91 per film) would offset the cost of the modification in 6 months, assuming the use of two films per study and 200 studies per month.

We are currently using only 4 × 5-in. films for our rectilinear scan images and find them to be completely satisfactory.

REFERENCES

1. LANGAN JK, WAGNER HN: A system to record, view, store and distribute nuclear medicine images and records. *J Nucl Med* 14: 588-590, 1973
2. MISHKIN FS, REESE IC, DOWELL JW: Advantages of producing a minified scan image. *Am J Roentgenol Radium Ther Nucl Med* 109: 682-685, 1972